

E P25E High-Temperature Choke

5 000 psig / Max Cv 45 / Max Bean Size 103

VALVE SPECIFICATIONS

This choke-valve option, suitable for high-temperature applications, uses a hammer-union nut to retain the bonnet and flow trim in the valve body. Standard end connections range in size from 2" to 4".

Valve Model	P25E HT
Body Type	Right Angle
Body Rating	5 000 PSIG (Maximum C.W.P.)
Inlet Connection	see 'Standard End Connections'
Outlet Connection	see 'Standard End Connections'
Bonnet Type	Hammer- Union Nut
Body / Bonnet Material	see 'Material Options'
Stem Material	see 'Material Options'
Seal Material	see 'Material Options'
Trim Style	Ported Cage with External Sleeve
Balanced / Unbalanced	Unbalanced
Flow Characteristic	Equal Percentage
Trim Material	see 'Trim Options'
Design Cv	see 'Trim Options'
Leakage Class	Class V (Standard)



TRIM OPTIONS

	Standard Trim Cage & External Sleeve 2 Row / 4 Hole
Material	UNS S17400, Stellite, Tungsten Carbide
Application	Liquid, Gas, Multiphase; Clean or Abrasive
Cv	45
Turns	12
Travel	1.50"

STANDARD END CONNECTIONS

Connection Size ▶	Standard Dimensions & Estimated Weights											
	2" Nominal				3" Nominal				4" Nominal			
	'I' or 'O'		Weight		'I' or 'O'		Weight		'I' or 'O'		Weight	
Connection Type ▼	inch	mm	lbs.	kg	inch	mm	lbs.	kg	inch	mm	lbs.	kg
Threaded	4.50	114	82	37	n/a	n/a	n/a	n/a	n/a	n/a	n/a	n/a
ASME 150 RF	7.00	178	92	42	7.25	184	103	47	7.50	191	115	52
ASME 300 RF	7.25	184	96	44	7.62	194	114	52	7.88	200	135	61
ASME 600 RF	7.62	194	100	45	8.00	203	116	53	8.75	222	156	71
ASME 600 RTJ	7.69	195	100	45	8.06	205	116	53	8.81	224	156	71
ASME 900 RF	8.75	222	128	58	8.75	222	138	63	9.25	235	184	84
ASME 900 RTJ	8.81	224	128	58	8.81	224	138	63	9.31	237	184	84
ASME 1500 RF	8.75	222	128	58	9.38	238	176	80	9.62	244	220	100
ASME 1500 RTJ	8.81	224	128	58	9.44	240	176	80	9.69	246	220	100
2 000 API 6B **	7.69	195	100	45	8.06	205	116	53	8.81	224	156	71
3 000 API 6B **	8.81	224	128	58	8.81	224	138	63	9.31	237	184	84
5 000 API 6B **	8.81	224	128	58	9.44	240	177	80	9.69	246	220	100

2-1/2" connections also available.

** Not API monogramable due to temperature range.

ENVELOPE DIMENSIONS

Dimensions 'A', 'B', and 'C' apply to manually operated chokes and are tabulated below. 'I' (inlet) and 'O' (outlet) dimensions depend on the end connections and are tabulated above. Special dimensions and other end connections are available upon request.

Dimensions		
	inch	mm
A	15.88	403
B	18.00	457
C	21.94	557

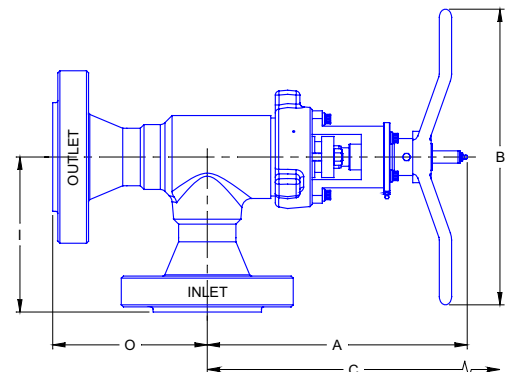

Note: "C" is the disassembly clearance.



MATERIAL OPTIONS

Temperature Class	Certification Level	API - 6A Material Class Designations							
		AA	BB	CC	DD	EE	FF	HH	
PU -20F to 250F PX -20F to 350F	STD / PSL-1	BB	BB	CC	n/a	n/a	n/a	n/a	
	PSL-2	BB	BB	CC	n/a	n/a	n/a	n/a	
	PSL-3	BB	BB	CC	n/a	n/a	n/a	n/a	

	BB-General Service	CC-General Service
Body	AISI 8620	AISI 316 *
Bonnet	ASTM A350 LF2	AISI 316
Stem	UNS S17400	UNS S17400
Bolting	AISI 4130	AISI 4130
Retaining Sleeve	ASTM A743 CF8M	ASTM A743 CF8M
Seals	Graphoil	Graphoil

Other materials available upon request.

* Not available for API-rated valves.

OTHER VALVE OPTIONS

	Standard	Optional
Calibration Head / Serial Plaque	Aluminum	Stainless Steel
Outlet Sleeve	-	Stainless Steel, Tungsten Carbide
Body Bleed Port	-	1/2" NPT, API Autoclave

Some limitations may apply.

ACTUATION OPTIONS

Master Flo	Other
Manually Operated (Stemlock is optional)	Pneumatic Piston
	Pneumatic Diaphragm

Other actuators available upon request.

PERFORMANCE CHARACTERISTICS

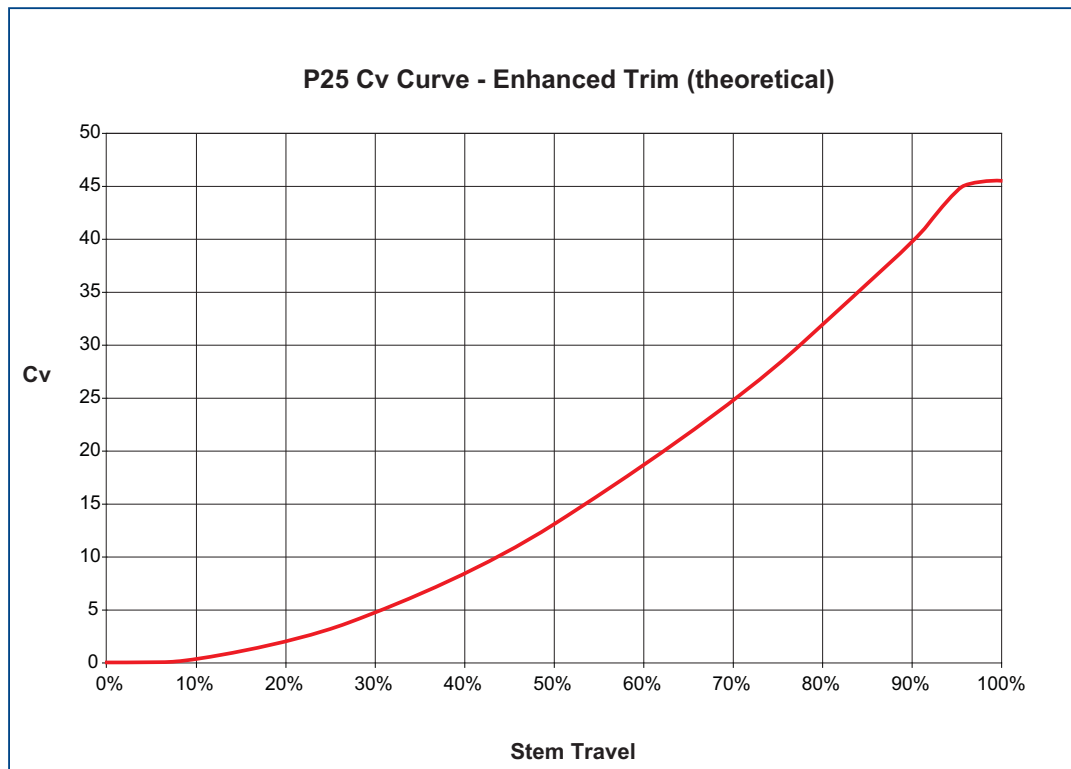

LIQUID PRESSURE RECOVERY FACTOR (FL)

Master Flo's trim geometry has been designed to achieve high F_L numbers. This results in a decreased cavitation potential, lower noise generation, increased flow capacity, and longer trim life. The high F_L numbers of Master Flo's trims have been verified experimentally as per the test procedures of ISA-S75.02-1996.

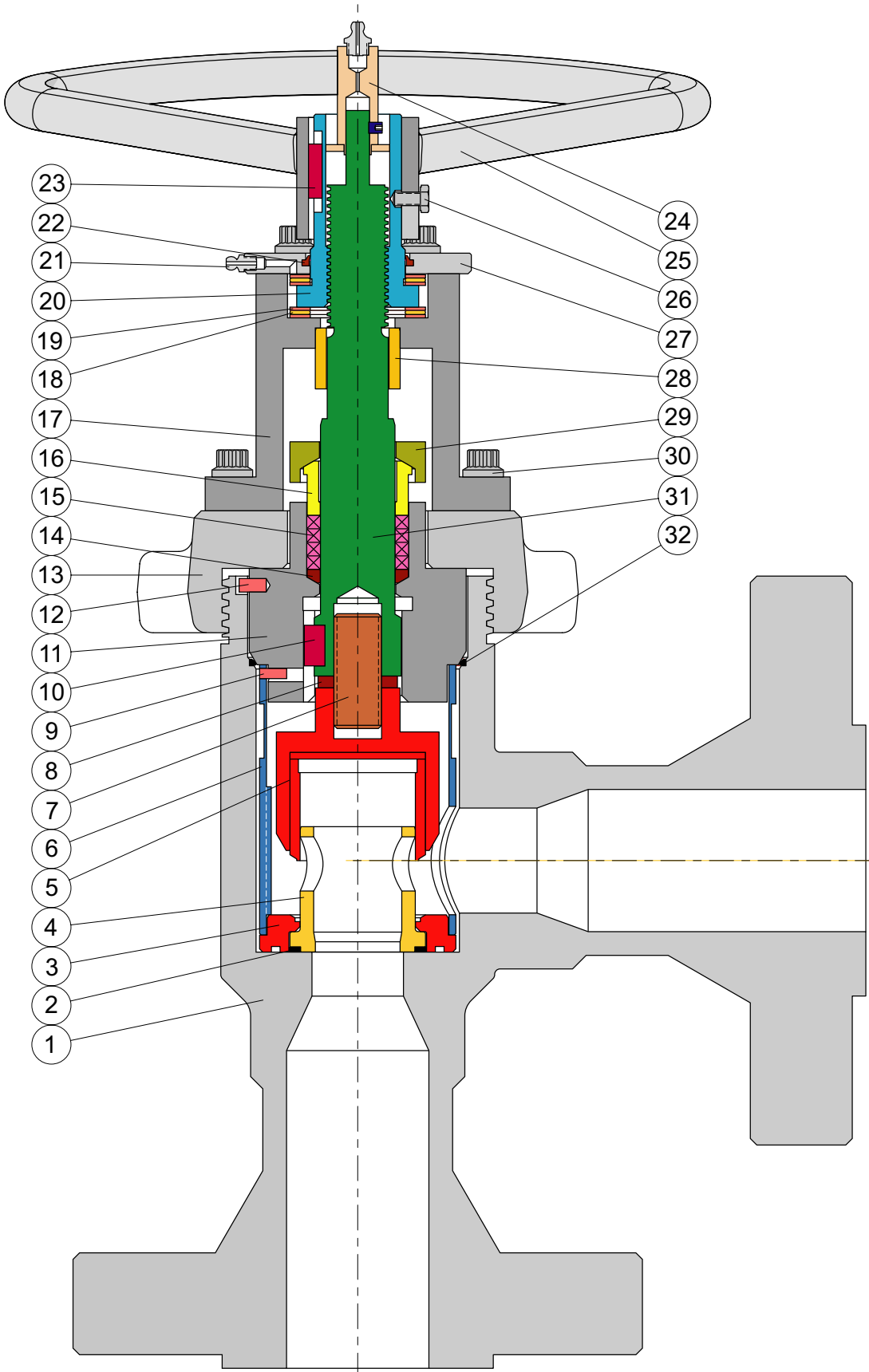

PARTS LIST

1. Body
2. Seal: Nozzle/Seat - Body
3. Seat
4. Cage
5. External Sleeve
6. Retaining Sleeve
7. Stud
8. Lockwasher
9. Pin
10. Key
11. Bonnet
12. Pin
13. Bonnet Nut
14. Packing Leader
15. Packing
16. Packing Follower
17. Yoke
18. Thrust Bearing
19. Thrust Washer
20. Stem Nut
21. Grease Nipple
22. Wiper
23. Key
24. Calibration Head
25. Handwheel
26. Capscrew
27. Cover Plate
28. Yoke Sleeve
29. Packing Gland
30. Capscrew
31. Stem
32. Metal Bonnet Seal
33. Nut (not visible)
34. Stud (not visible)

P25 Product Family

Standard:

- P25E - Hammer-Union Bonnet; 5 000 PSI

Other Options:

- P25E BB - Bolted Bonnet; 6 000 PSI
- P25E 15k - Bolted Bonnet; 15 000 PSI
- **P25E HT - Hammer Union; 5 000 PSI; High-Temperature Service**
- C25E - Hammer Union; 3 600 PSI; Inline
- C25E BB - Bolted Bonnet; 3 600 PSI; Inline
- C25E HT - Hammer Union; 3 600 PSI; Inline; High-Temperature Service

chokes for all applications

recycle lines



vent valves



manifold



production



blow down

glycol injection

overboard dumps



subsea



level controllers

water injection

